

Bidirectional Single Phase Off-line Inverter XP Series

E2L[®]

P312E



Bidirectional, Modular, Single Phase, Off-Line Solar inverters in 6 KW to 10 KW per unit for Off-Grid & Weak-Grid Applications (European and North American Models)

The P312 Series (ESIB01XP), offers a range of modular inverters from 6 KW to 10KW ideally suited for applications where energy feed-in to the grid is required.

Features include among others, the possibility of dual output to prioritize critical load over standard load in case of low battery conditions.

Units may be connected in parallel (up to 9) to increase power in single phase or in three phase configurations.

The P312 series include USB or RS232, Dry contact, RS485 and Wifi for Cloud communication to connect by hardware or software to other control devices while providing an easy web interface to the end-user.

The ESIB01XP™ Inverter Series

The ESIB01XP inverters are built in modules of 6KW and 8KW for the European market (230Vac) and Units in 6KW and 10KW 6KW each that can be connected in parallel in single or three phase configurations to reach a maximum power of 1 x 55.8KW (9 x 6.5 KW) in single phase or 3x19.5KW (3 x 3 x 6.5KW) in three phase configuration.

The ESIB01XP inverters are battery agnostic allowing them to be used with any type of battery (Lead Acid, ELA, Lithium, ...). The ESIB01XP inverters operate modular battery units that can also be increased based on client needs. They allow the user to gradually upgrade in either power or Battery size at will in order to gradually adapt the system with his growing energy needs.

The ESIB01XP inverters are fitted with a WiFi wireless connection that connects the client to an application allowing him to remotely monitor his energy system. They are highly compact and efficient allowing substantial savings in space and energy.

The ESIB01XP™ Inverters exceptional design meets basic modern requirements in terms of energy efficiency and environmental friendly applications for homes and small businesses.

E24's inverters employ transformerless high-frequency technology to offer the highest efficiency while remaining silent during its operation.



- **IP65 (Outdoor Installation)**
- **Dual AC Output (ESIB01XP-6KI - Other models optional)**
- **120 to 550 Vdc solar input**
- **Programmable Supply Priority: PV, Battery or Grid**
- **User Adjustable charging current and voltage**
- **Programmable Operation Modes: Grid-Tie, Off-Grid, and Grid-Tie**
- **Super compact**
- **Works with or without solar panels**
- **Wide Utility/Generator input voltage**
- **Intuitive large LCD display**
- **Seamless unattended operation**
- **Pure Sine Wave Output**
- **200% start-up power (overload) capacity**
- **Up to 95 % efficiency**
- **Unity power factor**
- **Up to 9 Units in Parallel**
- **Multiple Communication Ports (USB or RS232, Dry Contacts, RS485, Wifi)**
- **Battery Equalization to extend battery life**
- **USB-ON-THE-GO function**
- **Easy Replaceable Fans**
- **OPTIONAL Automatic control of Generator**
- **Can be combined for single or three phase operation**

ESIB01XP-3K6I
ESIB01XP-6KI
ESIB01XP-6KD

The ESIB01XP™ Unmatched Features

The ESIB01XP™ Hybrid Inverter Series is engineered to adapt to almost multiple existing number of energy sources in a manner to optimise energy costs and minimize generator operation while offering immediate power backup to the user.

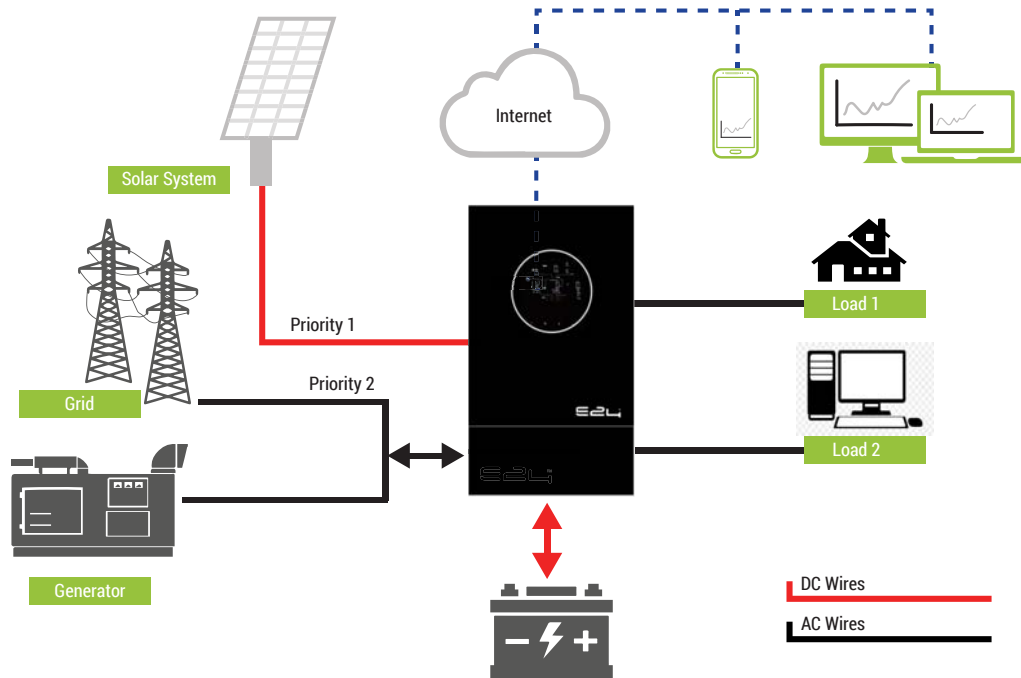

E24 Bidirectional inverter with Dual Output Topology

Works with or without solar panels

The ESIB01XP inverters charge the batteries from either the solar energy or the utility supply/back-up generator. If you do not install solar panels, the unit will still operate by only charging from your utility/generator. Off-course we recommend that you install solar panels in order to save on the cost of fuel and utilities.

Wide Utility/Generator input voltage

The ESIB01XP inverters accept a wide range of input voltage to remain fully compatible with your utility and generator voltage outputs

Intuitive large LCD display

The ESIB01XP inverters have a built in LCD display that provide intuitively all the data about the generated, stored or consumed energy.

Super compact - Fits Anywhere

The ESIB01XP inverters are wall mounted taking only 40cm height by 30cm width on your wall. The battery can be installed at a few meters away in an attic or an unused space in your home or business.

Programmable priority of energy sources:

The ESIB01XP™ may be programmed by default to priorities the energy source available to either supply the load directly or charge the batteries. Any unused renewable energy generated may be fed back to the grid for Net-metering benefits. Other priority configurations can be programmed at will.

Programmable Operation Modes: Operational Mode may be changed by software as desired: Grid-Tie, Off-Grid, and Grid-Tie with back-up.

Seamless, easy operation:

The ESIB01XP™ is engineered to operate without any user intervention. There is no need to push any buttons or understand how it works. It simply does.

Strong Overload Capability

The ESIB01XP™ Hybrid Inverter is capable of handling overloads of 110% - 125% / 150% for 10s / 5s respectively.

Power Walk In

Power Walk In function allows the rectifier of each unit to be turned on progressively and in sequences in order to avoid the sudden load on generators.

Dry Contacts

The ESIB01XP™ Series includes dry contacts that can be used to trigger certain actions like the automatic start-up of a diesel generator when battery is low and its shutdown when battery is charged.

Comprehensive Communication Options

Communications options include: RS232, RS485, Modbus (option), SNMP adaptor (Option), Dry Contacts, Wifi

Low input current total harmonic distortion (THDi)

The ESIB01XP™ Hybrid Inverter Series actively manages the input current total harmonic distortion (THDi) at a low level (2 percent at 100 percent load). E24's unique technology neutralizes the emission of harmonics at the input of the Hybrid Inverter system, providing greater reliability of operations for circuit breakers and extending the overall service life of the equipment. Low harmonic distortion saves unnecessary over sizing of gensets, cabling and circuit breakers, avoids extra heating of input transformers and extends the overall service life of all Hybrid Inverter stream components.

DSP Technology

The ESIB01XP™ Hybrid Inverter is built on advance Digital Signal Processing technology in order to provide high performance steady and accurate operation over its lifetime while offering outstanding efficiency (up to 96% in online mode).

Standards

The ESIB01XP™ Hybrid Inverter complies to EN 60950-1 standards.

Intelligent Battery Management

The ESIB01XP™ Hybrid Inverter includes an intelligent battery charger that includes a float/boost charger and a dynamic cut-off level that reduces battery maintenance and improves battery life.

Modularity up to 9 units

Up to 9 units can be positioned in parallel to either increase power in single phase or provide a maximum power out in either single-phase or three-phase configurations.

Wide Solar Input Voltage Range

Most inverters of small power capacity have an input voltage from solar PVs limited to 100-150Vdc maximum. This limits the numbers of Solar panels that be installed in series rather than in parallel which decreases the energy generation performance. The ESIB01XP inverters can accept Solar input voltage from 90 to 450Vdc (MPP tracking). Max Solar DC voltage is 500Vdc.

Fully Protection

The ESIB01XP is fully automated with large number of protection features built-in. The unit includes surges arrestors and input fuses to protect against input surges. The unit also includes overload protection circuitry that is easily user resettable in case of inadvertently connecting a load above the unit capacity.

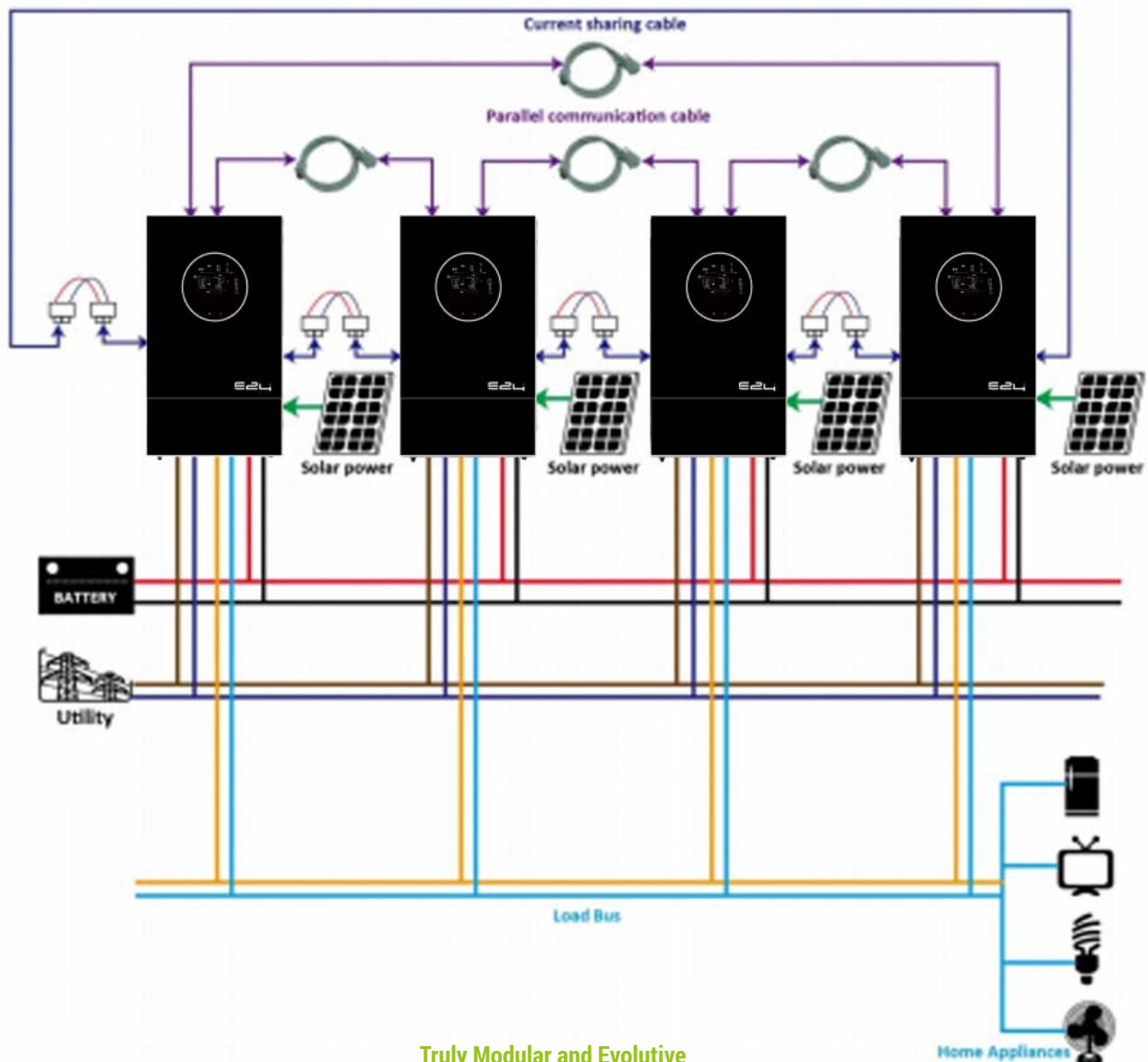

Pure Sine Wave Output

The unit provides an impeccable Sine wave output with no noise or any possible interference with your appliances or equipment.

200% start-up power capacity

When turning on electrical equipment, some have high in-rush current at start-up. Air conditioning units, pumps, motors, laser printers, photocopiers, are typical examples of high in-rush current equipment. The ESIB01XP are capable of providing twice the rated capacity of the inverter during the starting up of your equipment allowing you to save on the size of the inverter required.

Up to 96 % efficiency

The ESIB01XP use the latest high frequency SPWM technology to provide the highest operation efficiency bring the highest possible return on investment.

Unity power factor

An inverter of 3KVA with a power factor of 0.8 is in reality a 2.4KW inverter. E24 inverters are rated at unity power factor delivering 3KW for 3KVA inverters and 5KW for 5KVA inverter and so on.

Multiple Communication Ports (Wifi, RS485, RS232, Dry Contact for BMS)

Communication ports are used to exchange information between different systems in order build a fully integrated solution. When using lithium batteries, it is necessary for the batteries to exchange information with the inverter. Similarly, when using an E24 optional Energy Storage controller, it is necessary for the controller to read information from the inverter and battery for it to take the proper decisions (for example start the generator etc...)

Battery Equalization to extend battery life

When operating multiple batteries in series for a given time, some batteries may be slightly more charged than others. As a result the entire system may loses some of its performance due to the fact that batteries are not 100% equal to each other. The ESIB01XP includes an internal algorithm that forces batteries to equalize which substantially increase system performance and battery life.

USB-ON-THE-GO function

The ESIB01XP include a USB port to plug a USB drive in order to download historical data of the system that can be used for analysis and to rapidly program the inverter from a laptop.



USB-ON-THE-GO Function

Dual Output (ESIB01XP-6KI Only)

ESIB01XP-6KI has 2 separate outputs allowing the user to perform load management where one output is at a higher priority than the other. This offers users the option to disconnect one output in the event where battery is starting to deplete in order to extend runtime on the priority output.

Easy Replaceable Fans

One of the components that must be replaced with time on inverters are the fans that run continuously. These fans must be easy to replace in order to avoid downtime. The ESIB01XP is engineered in a way to allow easy replacement of the fans with minimal complexity and downtime.

OPTIONAL Automatic control of Generator

When used with the E24 optional Energy Controller it is possible to automatically start and stop an auxiliary generator in the event where the power drawn by the load either exceeds a preset level or when batteries start to be depleted.

The controller will automatically shuts down the generator when the load is decreased below the preset maximum load or when the battery capacity is restored.

ESIB01XP™ Technical Specifications (European Models in 230Vac)

Line Mode Specifications	Inverter Model	ESIB01XP-6KI	ESIB01XP-8KI	
	Input Voltage Waveform	Sinusoidal (utility or generator)		
	Nominal Input Voltage	230Vac		
	Low Loss Voltage	170Vac±7V (UPS); 90Vac±7V (Appliances)		
	Low Loss Return Voltage	180Vac±7V (UPS); 100Vac±7V (Appliances)		
	High Loss Voltage	280Vac±7V		
	High Loss Return Voltage	270Vac±7V		
	Max AC Input Voltage	300Vac		
	Nominal Input Frequency	50Hz / 60Hz (Auto detection)		
	Low Loss Frequency	40±1Hz		
	Low Loss Return Frequency	42±1Hz		
	High Loss Frequency	65±1Hz		
	High Loss Return Frequency	63±1Hz		
	Output Short Circuit Protection	Circuit Breaker		
	Efficiency (Line Mode)	>95% (Rated R load, battery full charged)		
Transfer Time	10ms typical (UPS); 20ms typical (Appliances)			
Power Limitation				
Charge Mode Specifications	Charging Algorithm	3-Steps		
	Utility Charging Mode			
	Programmable Utility Charging Current (A)	120	120	
	Max. Battery Charging Current (A)	120	120	
	Charging Floating Voltage	54Vdc		
	Solar Charging Mode			
	Maximum Solar Charging Current (MPPT)	120	120	
	# of MPPT x Max. PV Array Power (Wp) per MPPT	1 x 6500	1 x 8000	
	System DC Voltage	48 Vdc		
	Max. PV Array Open Circuit Voltage	500Vdc (MPPT from 120 Vdc to 430 Vdc)		
	Standby Power Consumption	2W		
	DC Voltage Accuracy	+/-0.3%		
General Specifications	Communication Interface	USB or RS232, RS485, Wifi, Dry Contact x		
	Safety Certification	CE		
	Operating Temperature Range	0°C to 50°C		
	Storage temperature	-15°C~ 60°C		
	Dimension (D*W*H), mm	192 x 360 x 665		
	Net Weight, kg	22.5	32	

Invert Mode Specifications	Inverter Model	ESIB01XP-6KI	ESIB01XP-8KI
	Rated Output Power	6KVA / 6KW	8KVA / 8KW
	Maximum # of Units in Parallel Operation	9	
	Output Voltage Waveform	Pure Sine Wave	
	Output Voltage Regulation	230 Vac±5%	
	Output Frequency (Hz)	50/60 Auto sensing	
	Peak Efficiency	95%	
	Surge Power	5s@≥150% load; 10s@110%~150% load	
	Surge Capacity	2x rated power for 5 seconds	
	Nominal DC Input Voltage	48Vdc	
	Cold Start Voltage	46.0Vdc	
	Low DC Warning Voltage @ load < 20% @ 20% ≤ load < 50% @ load ≥ 50%	44.0Vdc 42.8Vdc 40.4Vdc	
	Low DC Warning Return Voltage @ load < 20% @ 20% ≤ load < 50% @ load ≥ 50%	46.0Vdc 44.8Vdc 42.4Vdc	
	Low DC Cut-off Voltage @ load < 20% @ 20% ≤ load < 50% @ load ≥ 50%	41.0Vdc 40.8Vdc 38.4Vdc	
	High DC Recovery Voltage	58Vdc	
	High DC Cut-off Voltage	60Vdc	
No Load Power Consumption	<50W		
Saving Mode Power Consumption	<15W		

Charging Controls	Voltage Setting	Battery Type	Float
			48
		Flooded/AGM/Gel	54
	Charging Curve		
	Dual AC Input Availability	Optional	Optional

ESIB01XP™ Technical Specifications (North American Models in 120Vac)

	Inverter Model	ESIB01XP-6KD	ESIB01XP-10KD	
Line Mode Specifications	Input Voltage Waveform	Sinusoidal (utility or generator)		
	Nominal Input Voltage (Vac)	127/220 Split Phase or 120/208 Split Phase		
	Low Loss Voltage (Vac)	85±7 (UPS); 70±7 (Appliances)		
	Low Loss Return Voltage (Vac)	90±7 (UPS); 80±7 (Appliances)		
	High Loss Voltage (Vac)	140±7		
	High Loss Return Voltage (Vac)	135±7		
	Max AC Input Voltage (Vac)	150		
	Nominal Input Frequency (Hz)	50 / 60 (Auto detection)		
	Low Loss Frequency (Hz)	40±1		
	Low Loss Return Frequency (Hz)	42±1		
	High Loss Frequency (Hz)	65±1		
	High Loss Return Frequency (Hz)	63±1		
	Output Short Circuit Protection	Circuit Breaker		
	Efficiency (Line Mode)	>92% (Rated R load, battery full charged)		
	Transfer Time	10ms typical (UPS); 20ms typical (Appliances)		
Power Limitation	<p>The graph plots Power (Y-axis) against Input Voltage (X-axis). The X-axis has markers at 90V, 170V, and 280V. The Y-axis has markers for 50% Power and Rated Power. The power starts at 50% at 90V, rises linearly to reach the Rated Power at 170V, and remains constant at the Rated Power level until 280V.</p>			
Charge Mode Specifications	Charging Algorithm	3-Steps		
	Utility Charging Mode			
	Programmable Utility Charging Current (A)	120	120	
	Max. Battery Charging Current (A)	120	120	
	Charging Floating Voltage (Vdc)	54.4		
	Solar Charging Mode			
	Maximum Solar Charging Current (MPPT)	120	120	
	# of MPPT x Max. PV Array Power (W) per MPPT	2 x 3750	2 x 7250	
	System DC Voltage (Vdc)	48		
	Max. PV Array Open Circuit Voltage (Vdc)	600 (MPPT from 120 to 550)		
	Standby Power Consumption (W)			
DC Voltage Accuracy	+/-0.3%			
General Specifications	Communication Interface	USB or RS232, RS485, Wifi, Dry Contact		
	Safety Certification	c ETL US		
	Operating Temperature Range	0°C to 50°C		
	Storage temperature	-15°C~ 60°C		
	Dimension (D*W*H), mm	215.5 x 515 x 700		
	Net Weight (kg)	41		

Invert Mode Specifications	Inverter Model	ESIB01XP-6KD	ESIB01XP-10KD
	Rated Output Power (KVA) / (KW)	6 / 6	10/10
	Maximum # of Units in Parallel Operation	6	
	Output Voltage Waveform	Pure Sine Wave	
	Output Voltage Regulation (Vac)	120 ±5%	
	Output Frequency (Hz)	50 / 60 (auto-sensing)	
	Peak Efficiency (Hz)	96%	
	Surge Power	5s@≥150% load; 10s@110%~150% load	
	Surge Capacity (KVA)	12	20
	Nominal DC Input Voltage (Vdc)	48	
	Cold Start Voltage (Vdc)	46.0	
	Low DC Warning Voltage (Vdc) @ load < 20% @ 20% ≤ load < 50% @ load ≥ 50%	44.0 42.8 40.4	
	Low DC Warning Return Voltage (Vdc) @ load < 20% @ 20% ≤ load < 50% @ load ≥ 50%	46.0 44.8 42.4	
	Low DC Cut-off Voltage (Vdc) @ load < 20% @ 20% ≤ load < 50% @ load ≥ 50%	41.0 40.8 38.4	
	High DC Recovery Voltage (Vdc)	58	
	High DC Cut-off Voltage (Vdc)	60	
	No Load Power Consumption (W)	<50	
	Saving Mode Power Consumption (W)	<15	

Charging Curve		
	Dual AC Input Availability	Optional

Hybrid

Storage Inverter

Battery



E24 Modular Range Of Products For Building Easy, Flexible & Evolutive Solutions

E24 products dynamically evolve with the lifestyle and work style of its customers while easing the installation process.

E24 products are conceived in modules allowing for an easy upgrade to adjust with the needs of the customers. Being modular and easy to connect E24 products allow installers to easily configure the required modules for an optimal solution while offering easy upgrade options.



Ordering Information

Ref Number	Description
EESIB01XP-6KI	Mod. Solar Bi-direct. Inverter, IP65, 48Vdc, 6KW, 1 Ph. ,Duel output, 230V, 50/60Hz, 6.5KWp, 500Vdc, Cloud Mon., USB,RS485, RS232,WiFi, Dry
ESIB01XP-6KD	Mod. Solar Bi-direct. Inverter, IP65, 48Vdc, 6KW, 1 Ph. 120V or 2Ph 208V ,output 208V, 50/60Hz, 2x3.75KWp, 600Vdc, Cloud Mon., USB,RS485, RS232,WiFi, Dry
ESIB01XP-8KI	Mod. Solar Bi-direct. Inverter, IP65, 48Vdc, 8KW, 1 Ph. ,Duel output, 230V, 50/60Hz, 2x4KWp, 550Vdc, Cloud Mon., USB,RS485, RS232,WiFi, Dry
ESIB01XP-10KD	Mod. Solar Bi-direct. Inverter, IP65, 538Vdc, 10KW, 1 Ph. 120V or 2Ph 208V ,output 208V, 50/60Hz, 2x7.25KWp, 600Vdc, Cloud Mon., USB,RS485, RS232,WiFi, Dry

E24[®]

www.e24solutions.com



ISO 9001:2015



QUALITY STANDARD

